



# Cryogenic Application Guide

Quality flow control products paired with expert advice.



- GLOBE VALVES
- GATE VALVES
- CHECK VALVES
- RELIEF VALVES
- HIGH PRESSURE VALVES
- NEEDLE VALVES
- DIVERTERS
- REGULATORS
- MANIFOLDS
- CYLINDER EQUIPMENT

# You do not thrive for more than 100 years because you are lucky.

It takes quality products, constant innovation, and above all a dedication to the customer.

From a pioneer in the development of oxygen regulators to a global leader delivering a comprehensive line of flow control and safety products, RegO has always kept our customers' interests first.

**Quality matters.** Industrial gas applications have no room for leaks. That is why we design and manufacture in the U.S., test 100% of our products, and can offer a 10-year warranty. RegO products offer performance you can rely on.

**Innovative products, processes and people.** We invest in technology and training to deliver flow control products designed to reduce your maintenance and replacement costs, and ensure an efficient, safe work flow.

**When our customers thrive, we do too.** Our experienced team can provide technical support and design assistance. We are here to help in any way, every day.



**Quality materials, innovative, long-lasting design and operational excellence** are built into every product we manufacture. That is how we can offer a 10-year product warranty—double that of other companies.



**Designed, manufactured and 100% tested** in the USA. Our four state-of-the-art facilities build the products that are most critical to your application.

## Contents

Air separation unit (ASU) products .....	3
Bulk tank storage .....	4
Transport trailers .....	6
Microbulk tank storage .....	8
Liquid cylinders .....	10
Liquid cryogenic delivery systems.....	12
Gas phase regulation stations .....	13
Electric transformer nitrogen delivery systems.....	14
High pressure gas tube storage and transport.....	15
High and medium pressure manifold and delivery systems.....	16
Gas delivery systems.....	17
Carbon dioxide delivery systems .....	18
Product certifications.....	19



## Air separation unit (ASU) products

### 24/7 production schedules demand 24/7 toughness

RegO valves, regulators and safety devices are engineered to stand up to the toughest environments and provide years of reduced maintenance and worry-free operation. When you have been designing and manufacturing your own products for more than 100 years, you pay attention to the details—like anti-corrosive, ergonomic hand wheels and leak-proof valves that deliver superior flow rates.



[www.regoproducts.com/cryo/](http://www.regoproducts.com/cryo/)

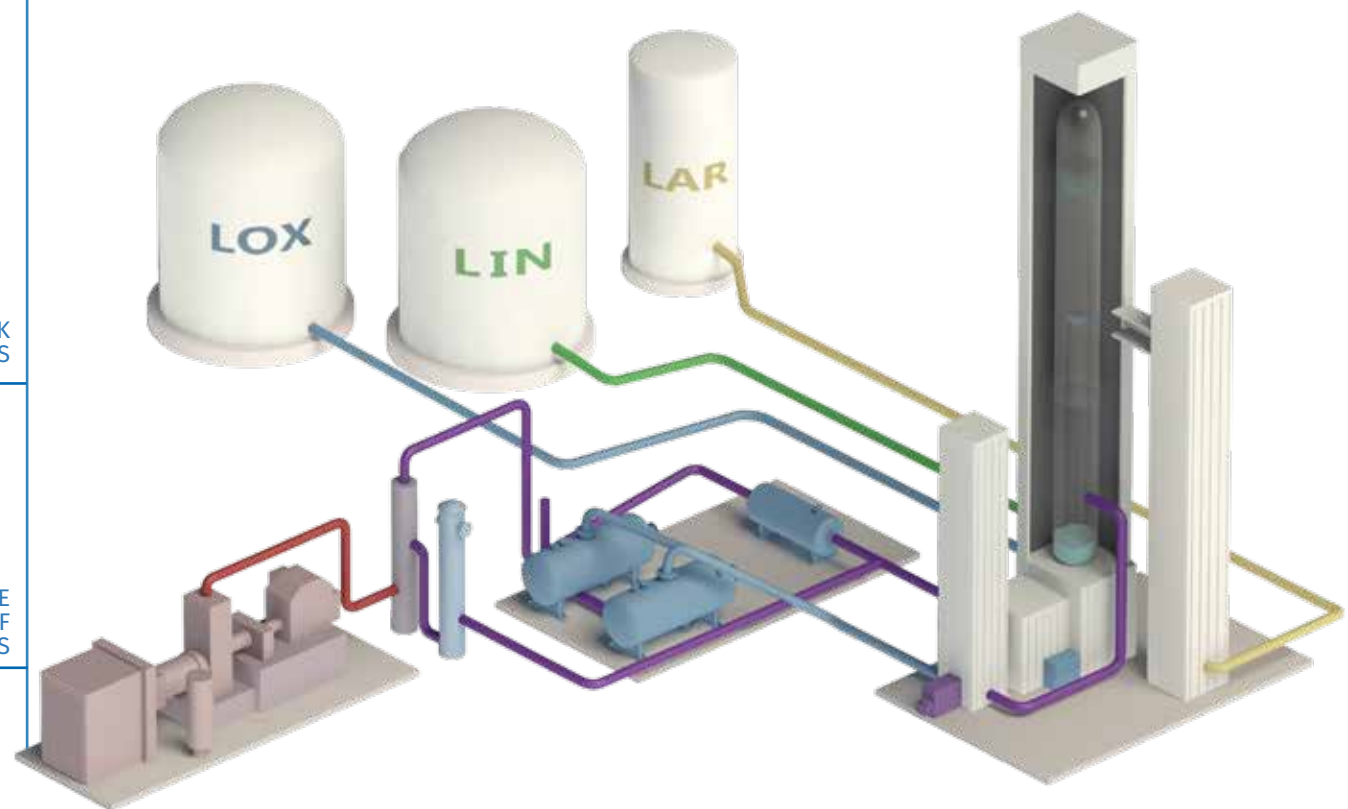
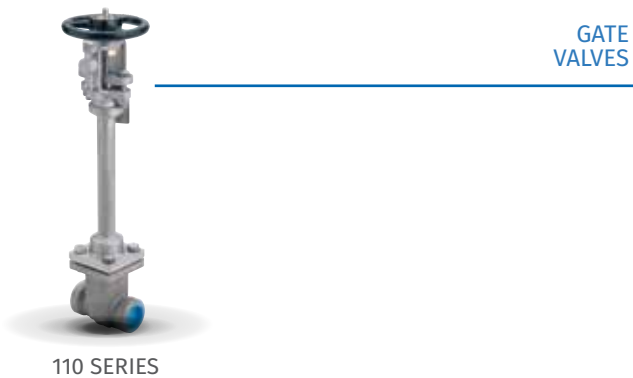

## Bulk tank storage

### Breadth of line meets depth of knowledge

Combine RegO's industry experience, design assistance and broad product line to build a flow control system that enables maximum efficiency and excellent value for bulk storage applications.

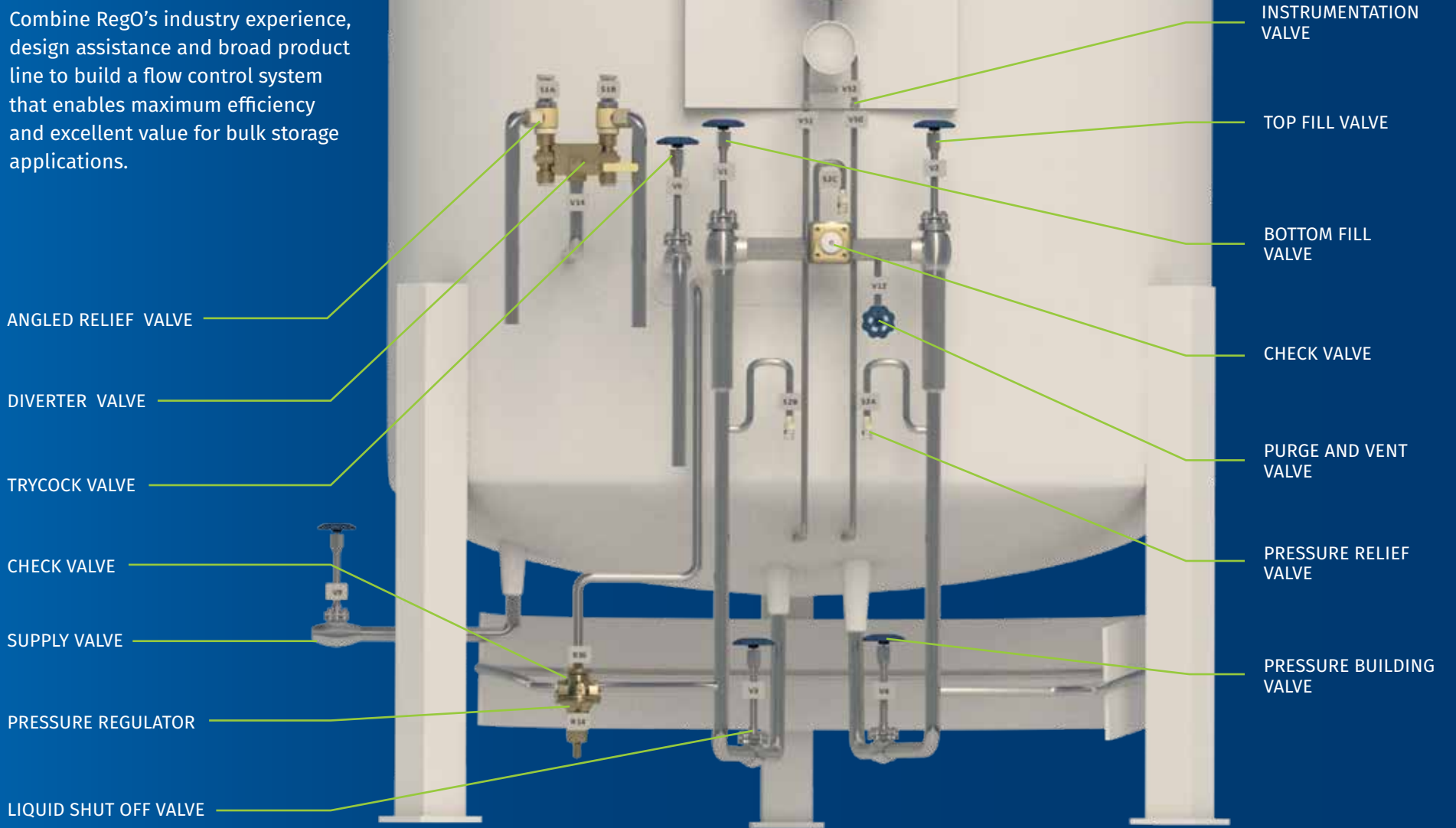

# REGO BULK TANK PRODUCTS

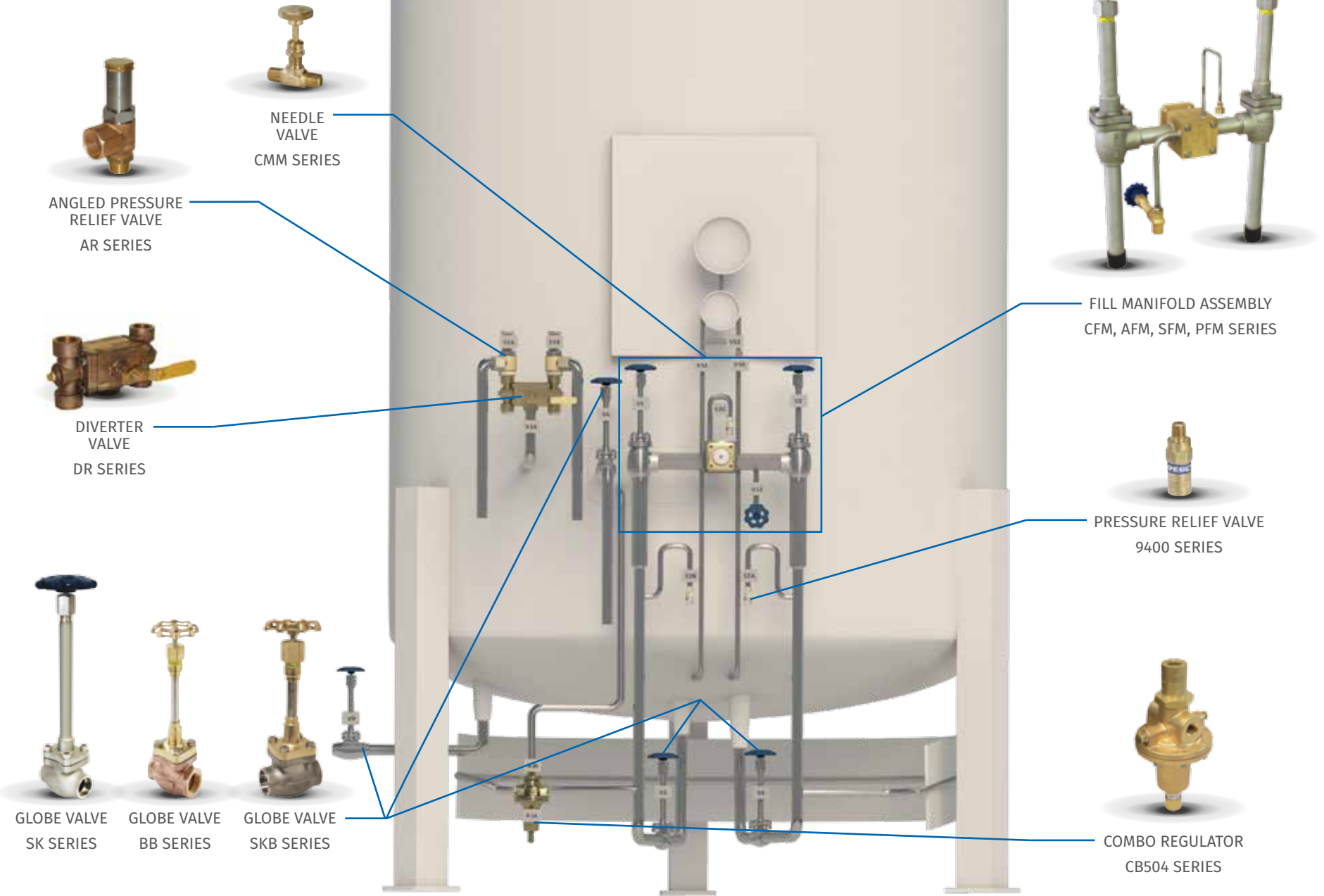

The illustrations in this application guide are intended to inform a professional installer/system designer where our products are generally installed on certain containers or applications. These illustrations are not intended for and must not be used for system design.

# Transport trailers

## Where safety and reliability intersect

RegO products are meticulously designed, manufactured and 100% tested in the U.S. to deliver quality performance mile after mile. We make loading, transporting and unloading efficient and safe to keep you rolling.

EMERGENCY SHUT OFF VALVE

RECIRCULATION VALVE

PRESSURE BUILDER VALVE

OUTLET PUMP VALVE

BOTTOM FILL VALVE

TOP FILL VALVE

INSTRUMENTATION VALVE

ANGLED RELIEF VALVE

VENT VALVE

ROAD VALVE

BACK PRESSURE REGULATOR

PRESSURE BUILDING CHECK VALVE

INLET PUMP VALVE

DISCHARGE CHECK VALVE

PRESSURE RELEASE VALVE

PURGE VALVE

FULL TRYCOCK

# REGO TRAILER PRODUCTS

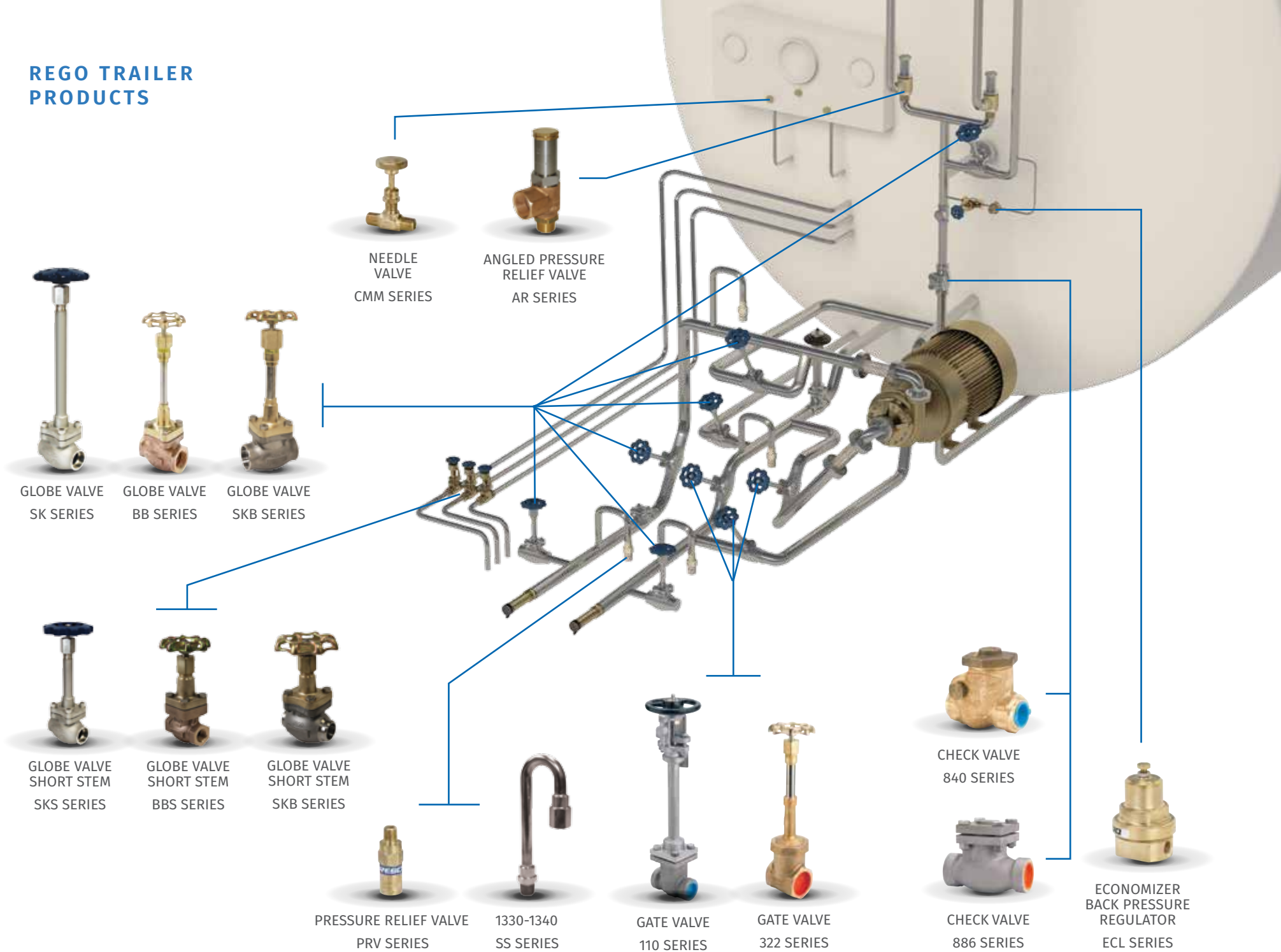

# Microbulk tank storage

## Quality comes in all sizes

Microbulks are ideal for operations that have outgrown cylinder storage solutions or need flexible installation. RegO quality assures a safe, steady supply—no matter what your storage needs are.

INSTRUMENTATION VALVE - GAS

INSTRUMENTATION VALVE - LIQUID

INSTRUMENTATION VALVE - EQUALIZER

RELIEF VALVE

ECONOMIZER ISOLATION VALVE

ECN ECONOMIZER

PB OUTLET VALVE

VENT / FULL TRYCOCK VALVE

LIQUID USE VALVE

HOSE DRAIN VALVE

BOTTOM FILL VALVE

RELIEF VALVE

TOP FILL VALVE

GAS USE VALVE

RELIEF VALVE

AUXILIARY GAS VALVE

RELIEF VALVE

PRESSURE BUILDING VALVE

STRAINER



# REGO MICROBULK TANK PRODUCTS

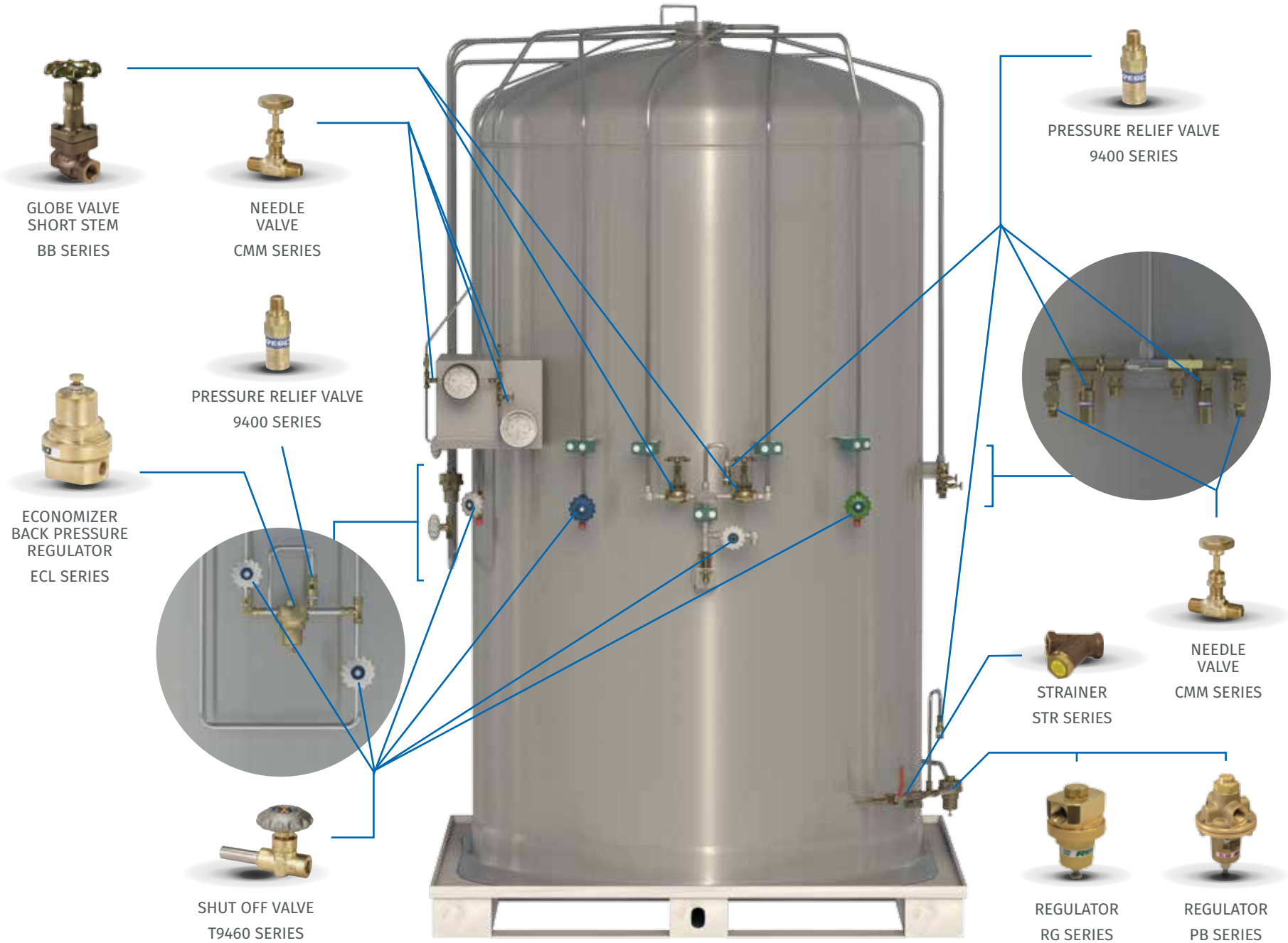

## Liquid cylinders

### We do not freeze under pressure

Cylinders can take a beating in transport and everyday use. RegO valves are the most widely used in the industry, and deliver a pressure-sealed barrier to avoid freeze-up and maintain constant flow. The robust design prevents maintenance requirements and avoids downtime, while safeguarding against over-torquing for long-lasting operation, with lower operational costs.

*Rated for liquid oxygen service per CGA G-4.1.*



PRESSURE BUILDING VALVE

LIQUID USE VALVE

ECONOMIZER/ PRESSURE BUILDING REGULATOR

VENT VALVE

PRESSURE RELIEF VALVE

GAS USE VALVE

# REGO LIQUID CYLINDER PRODUCTS

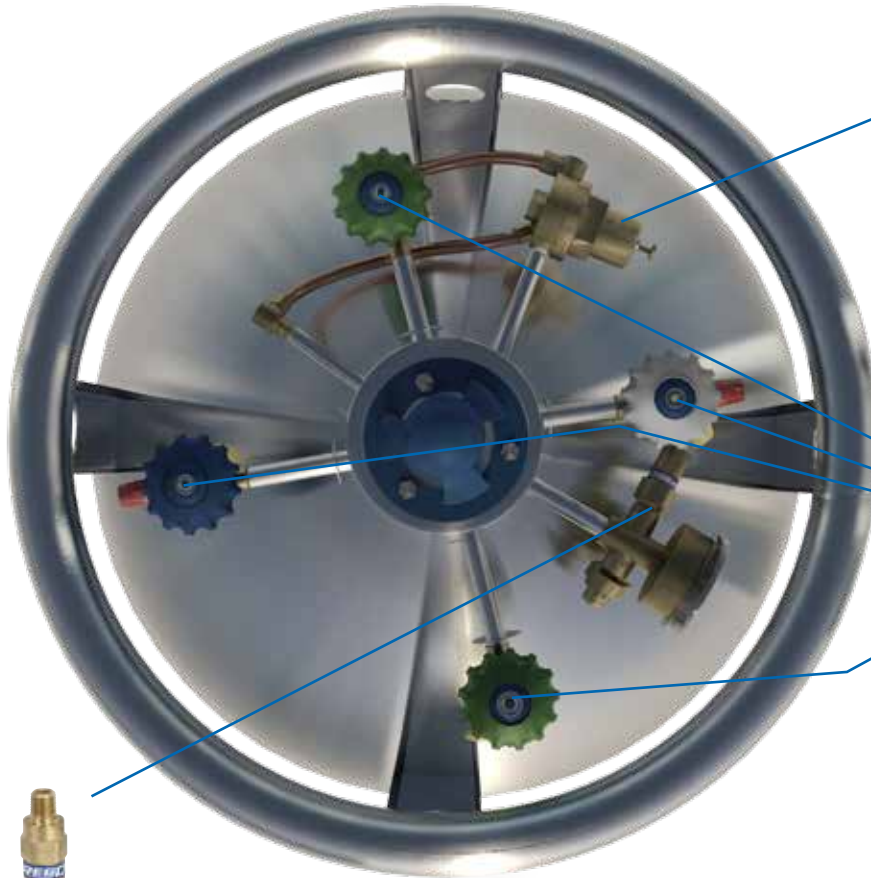

PRESSURE RELIEF VALVE  
PRV SERIES

COMBO REGULATOR  
CBC/CBH SERIES

SHUT OFF VALVES  
T9460 SERIES

SHUT OFF VALVES  
T9460 SERIES



The illustrations in this application guide are intended to inform a professional installer/system designer where our products are generally installed on certain containers or applications. These illustrations are not intended for and must not be used for system design.

# Liquid cryogenic delivery systems

## The key to fast freezing and fresher foods

Chilling, freezing, preservation and carbonation are just some of the ways cryogenic gases help preserve and transport foods and beverages. RegO flow control products are constructed for superior performance in demanding manufacturing environments.



NITROGEN INJECTION SYSTEMS FOR FOOD PRESERVATION AND FAST FREEZING

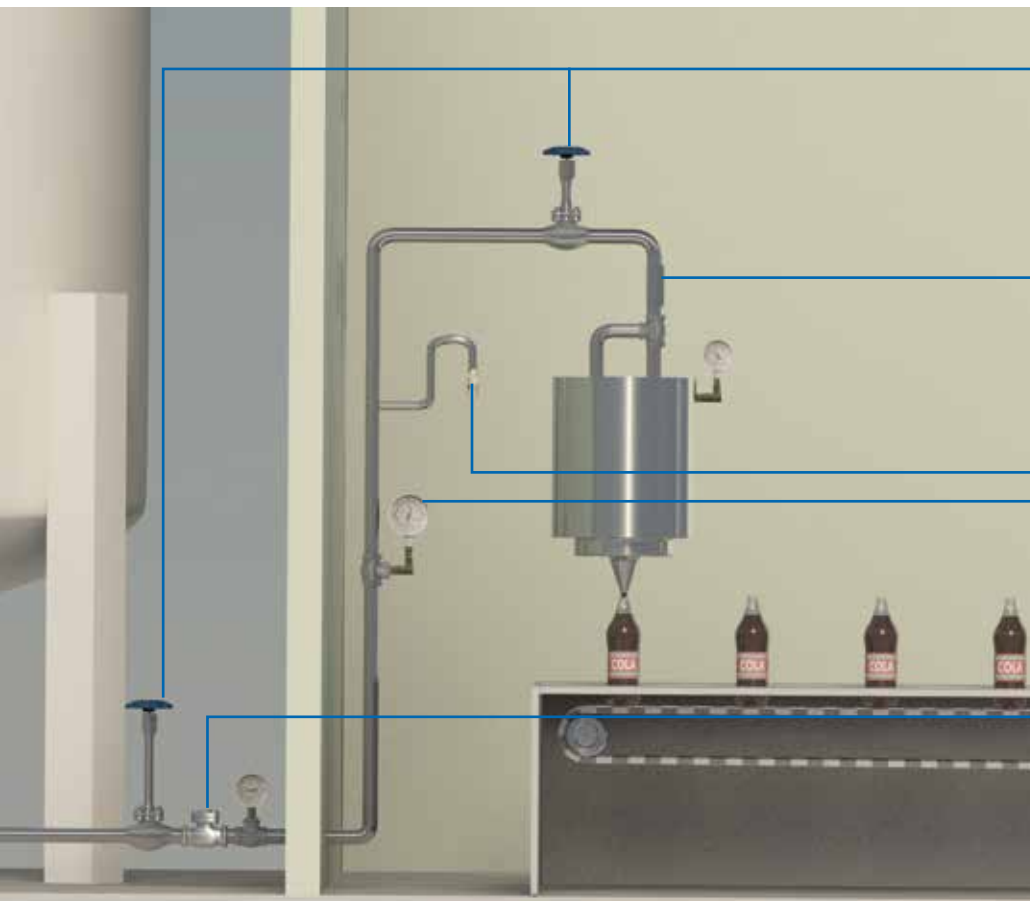

## Gas phase regulation stations

### On-demand use demands superior reliability

Durable RegO products provide years of efficient, low-maintenance gas flow from storage to application. In critical sectors such as healthcare, RegO quality can save money—and RegO reliability can save lives.

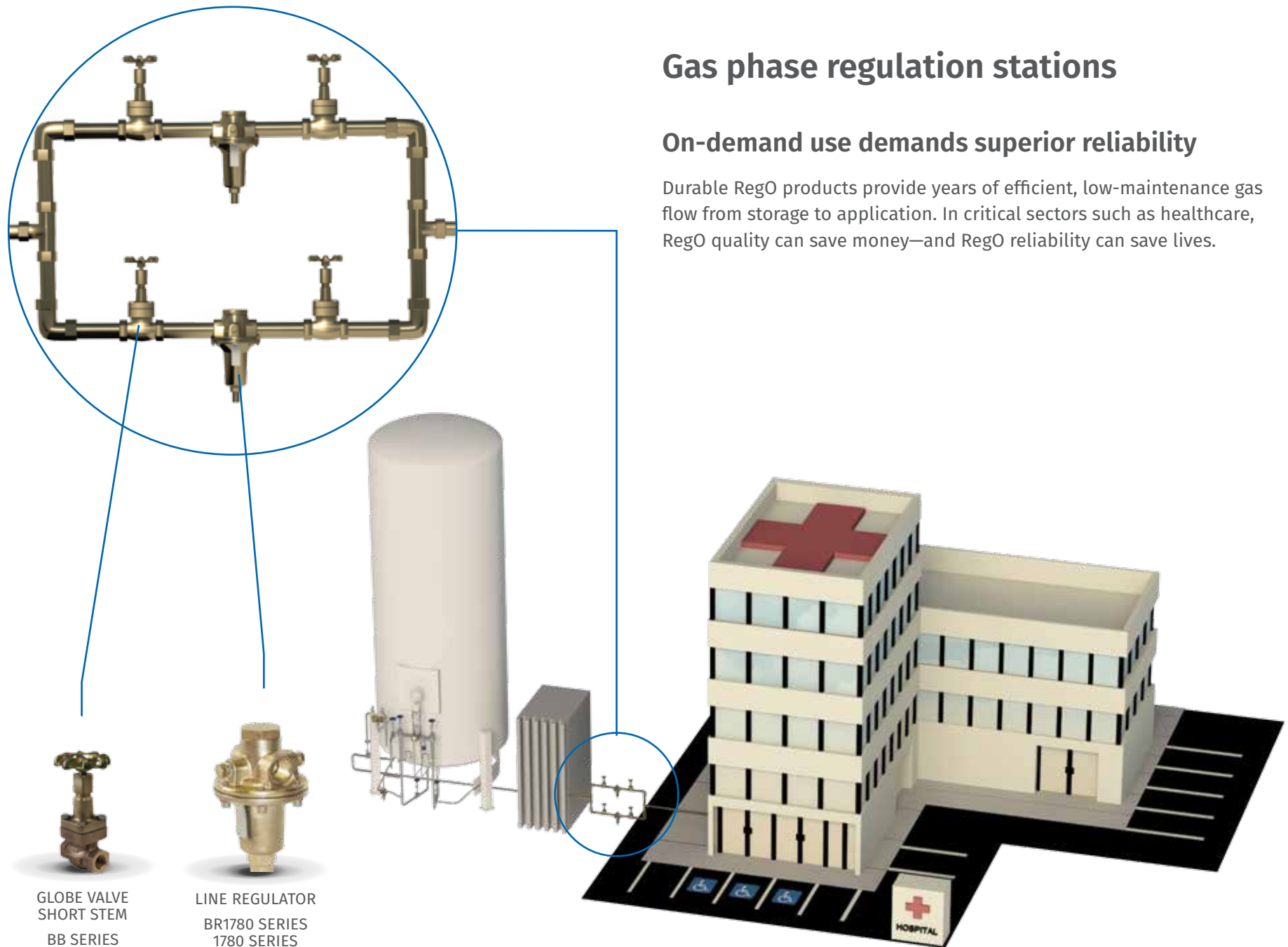

GLOBE VALVE  
SHORT STEM  
BB SERIES

LINE REGULATOR  
BR1780 SERIES  
1780 SERIES

## Electric transformer nitrogen delivery systems

### Keep the power flowing with RegO

RegO Inertrol™ systems deliver the constant supply of nitrogen needed to provide an inert gas seal in transformer applications, and prevent oxidation and humidity in the transformer oil—extending the lifetime of the unit. Built to withstand the elements and to safely adjust for changes in temperature, RegO systems can be integrated to trigger alerts for unexpected changes in pressure.



INERTROL OUTFITS  
4286, 4289, 4291 SERIES

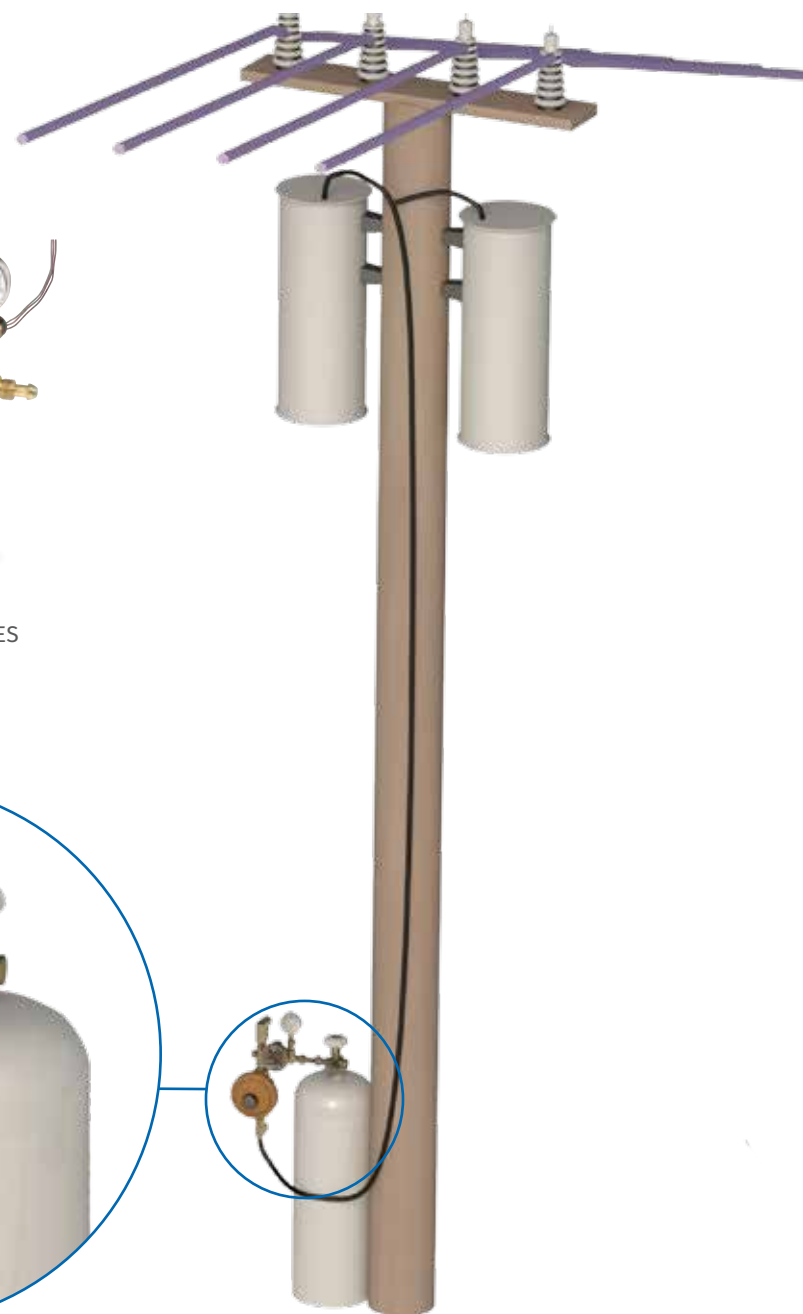
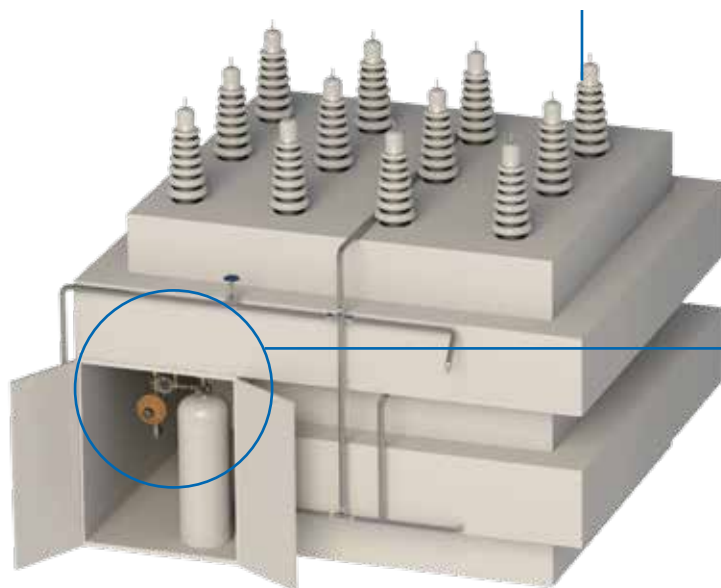

## High pressure gas tube storage and transport

### High pressure applications meet low maintenance solutions

Tube storage brings volume capabilities. A RegO valve brings years of safe, leak-free flow control to gas tube applications, as well as other high pressure manifold and piping systems. The HP9560 Series exhibits a very low operating torque under pressure for ease of manual operation.

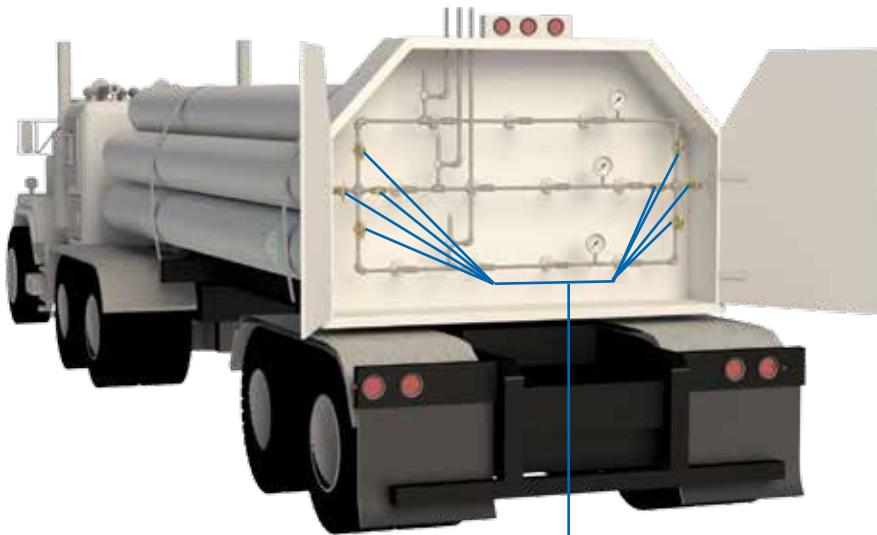

HIGH PRESSURE GAS  
MASTER VALVE  
HP9560 SERIES

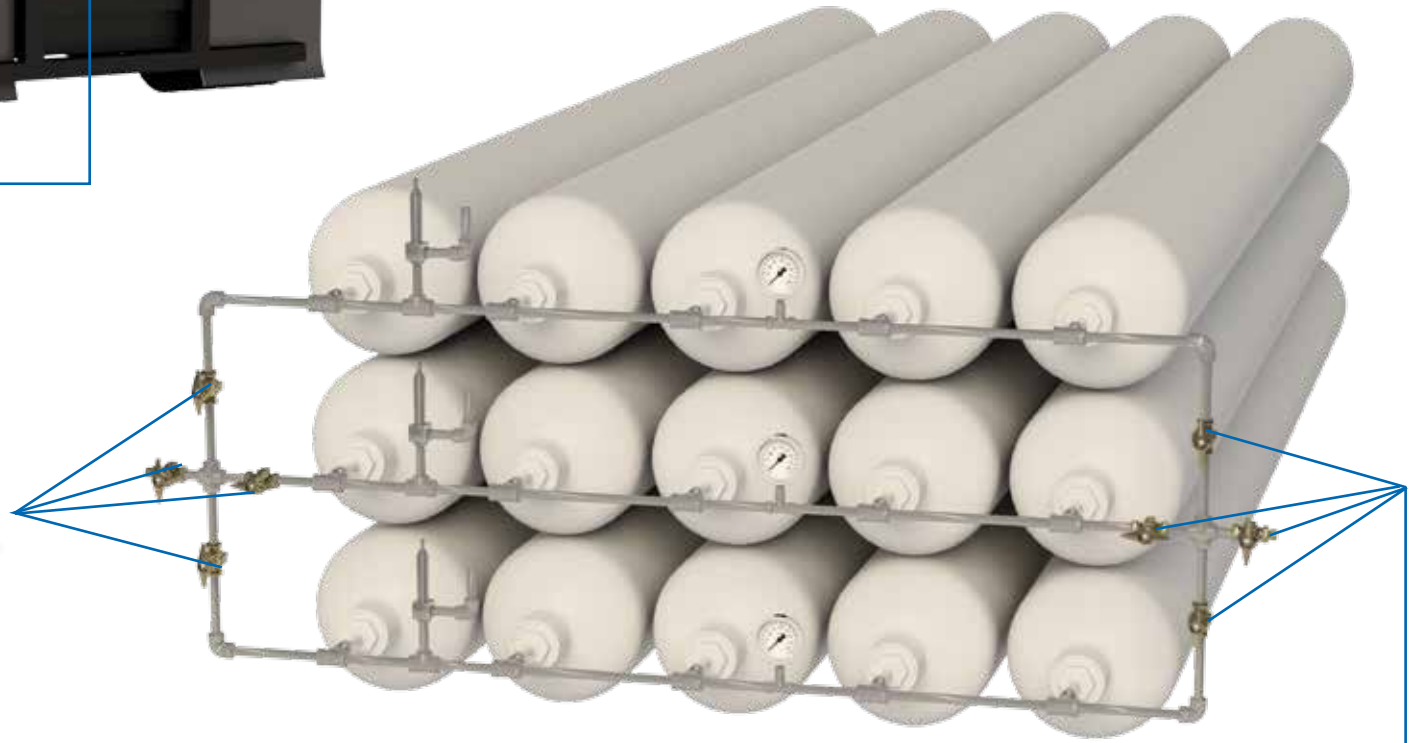

# High and medium pressure manifold and delivery systems

## We can handle all kinds of pressure

RegO has all the components you need to create your own system. Or you can tap our technical team's deep product and application knowledge and we will build to your specifications. Either way, you will get the benefit of RegO quality and innovation throughout to maintain steady pressure and excellent performance.

High pressure manifold and delivery systems

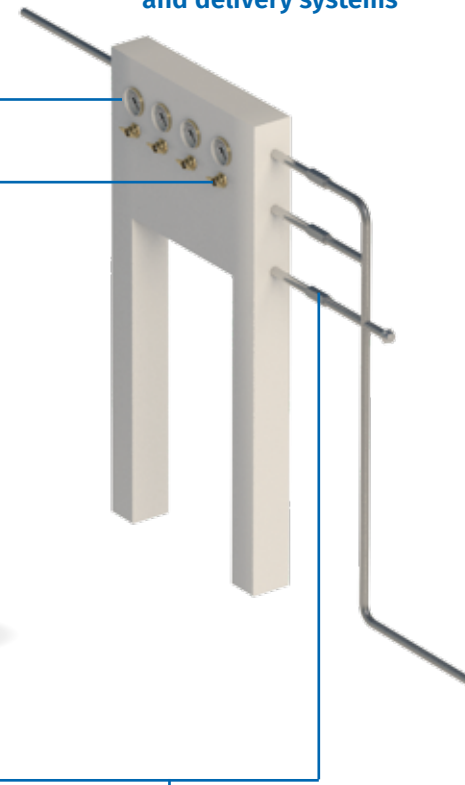

Medium and low pressure manifold and delivery systems

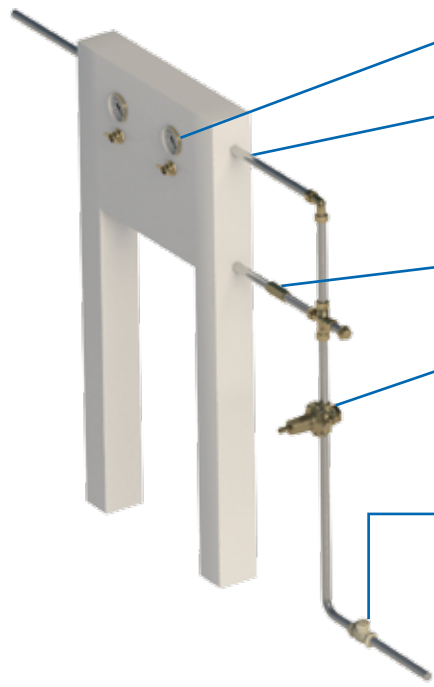

REGO ALSO OFFERS A COMPLETE SELECTION OF BRASS PIPE, ELBOWS TEES, CROSSES, CAPS AND PLUGS.



**COMPRESSED GAS MANIFOLD SYSTEMS**



**Gas delivery systems**

**Reliable, on-demand industrial gas**

RegO products manage gas for industrial applications, such as welding, cutting, heating and power generation. Through innovative design our products provide maximum reliability and precision to help fuel manufacturing processes and business profits.

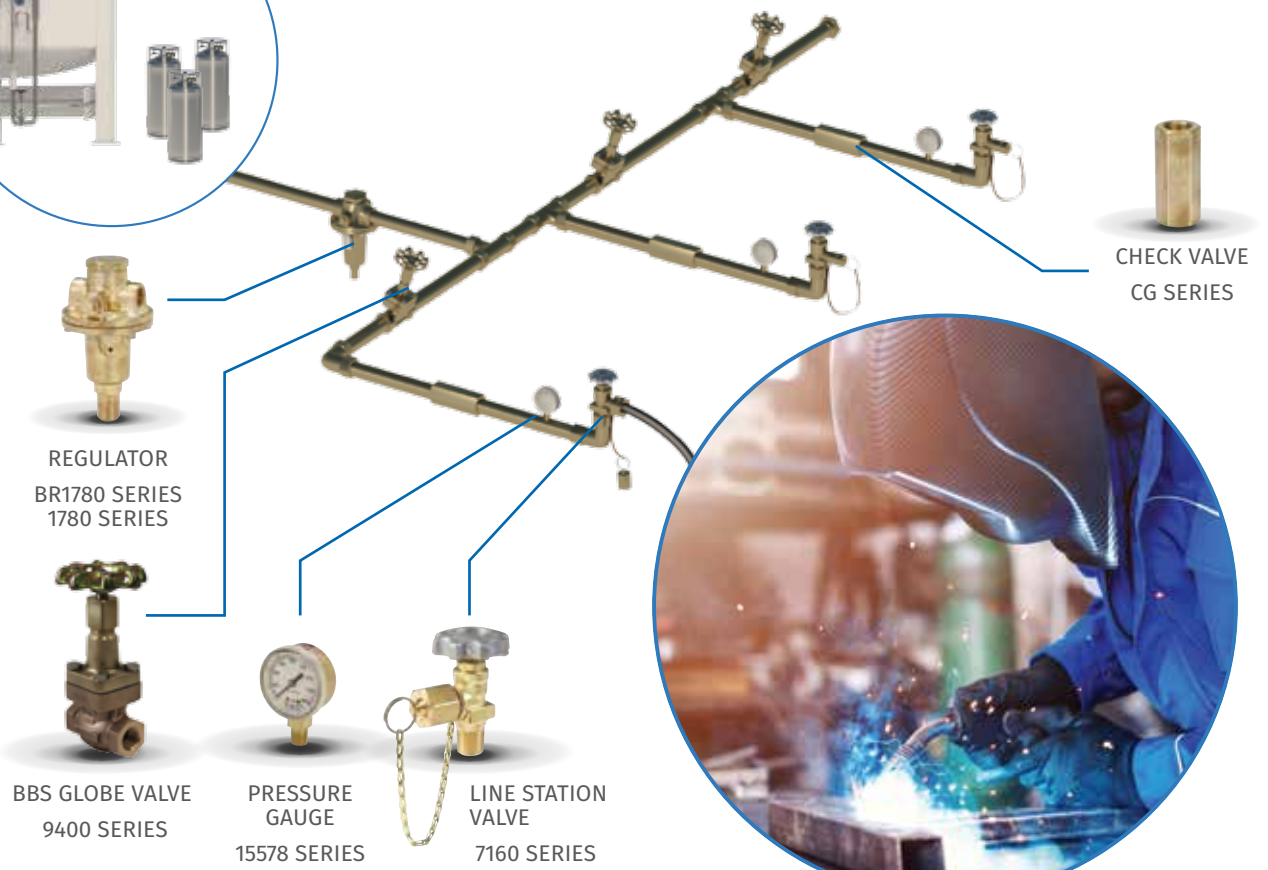

REGO ALSO OFFERS A COMPLETE SELECTION OF BRASS PIPE, ELBOWS TEES, CROSSES, CAPS AND PLUGS.

# Carbon dioxide delivery systems

We bring the “fizz” without the fuss

From the tank truck to the soda fountain, RegO products bring reliable, cost-effective carbon dioxide delivery—refill after refill.

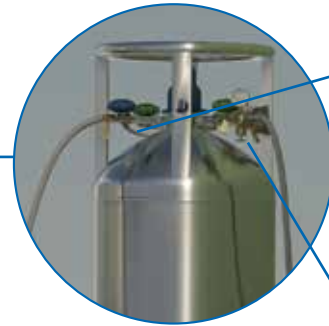

SHUT OFF VALVE  
T9460 SERIES



LIQUID CYLINDER  
REGULATOR  
FUEL GAS DELIVERY  
SYSTEMS  
LCR SERIES

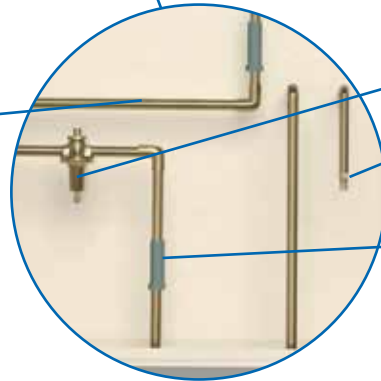

CARBON DIOXIDE  
RELIEF VALVES  
UA3149A SERIES



CHECK VALVE  
CG SERIES



ASME RELIEF VALVE  
C-19434B SERIES



LINE REGULATOR  
BR1780 SERIES  
1780 SERIES



PED Module D D1  
 VdTUV Cryo Safety Valve  
 VdTUV Cryo Shut Off Valve  
 PED Module B Safety Valves  
 TPED Cert AR NR PRV  
 TPED Cert Cryo Shut Off  
 SK Series TUV Cert 0036-068-17



UV & NB



Conflict-Free Sourcing Initiative



OA7770\_50346789NTY  
 CRN OC15296\_502346789NTY  
 OC7770\_502346789NTY  
 OG7770\_502346789NTY  
 OH7770\_5046789NTY  
 OC8040\_502346789NTY



Manufacturer License



10001523 REGISTERED FIRM ISO9001:2008

ENGINEERED CONTROLS

ISO 9001:2008



KGSC Certificate

## Product certifications

World-class quality—but do not just take our word for it.

RegO builds products that last. Our durable materials, proven designs, and rigorous testing, all add up to products designed for years of safe operation under hazardous conditions. With standards like these, it is no wonder that RegO quality is recognized the world over.

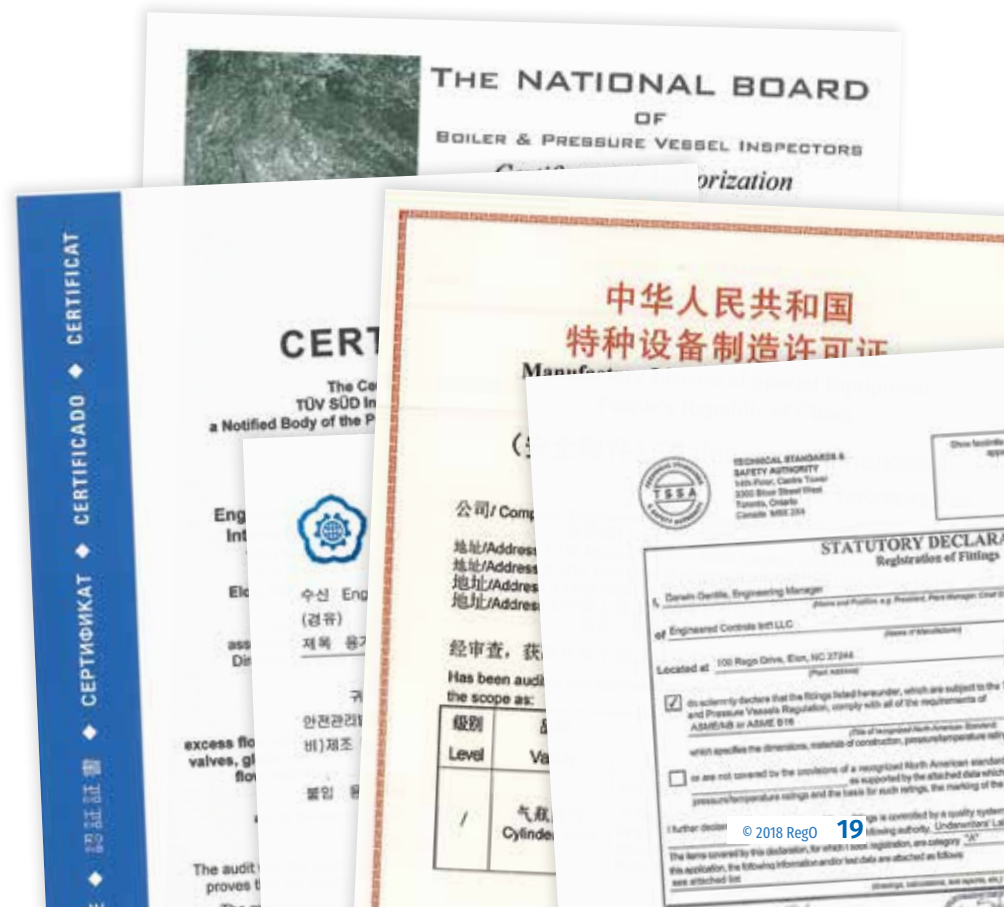



USA: Headquarters

Elon, NC USA  
Phone: +1 336 449 7707  
Email: [ecii@regoproducts.com](mailto:ecii@regoproducts.com)

Europe

Gladenbach, Germany  
Phone: +49 6462 9147 10  
Email: [info@rego-europe.de](mailto:info@rego-europe.de)

Latin America

Santa Catarina, Mexico  
Phone: +52 81 8032 5250  
Email: [volalde@regoproducts.com.mx](mailto:volalde@regoproducts.com.mx)

Asia

Shanghai, China, 200131  
Phone: +86 21 5046 2183,  
+86 21 5046 2012  
Email: [david.wang@rego-asia.com](mailto:david.wang@rego-asia.com)



**Quality materials, innovative, long-lasting design and operational excellence,** are built into every product we manufacture. That is how we can offer a 10-year product warranty—double that of other companies.



**Designed, manufactured and 100% tested** in the USA. Our four state-of-the-art facilities build the products that are most critical to your application.

For technical assistance contact: [support@regoproducts.com](mailto:support@regoproducts.com)

[regoproducts.com](http://regoproducts.com) | [rego-europe.de](http://rego-europe.de)